

# RCB SERIES

## Always safe, never sorry.

The RCB's spark resistant design is certified to ATEX standards to ensure safer lifting in dust-laden or explosive gas atmospheres. The RCB is specifically designed for use in petroleum, pharmaceutical and food industries, or any application where safety is improved by the use of anti-sparking equipment. Be sure to look for the ATEX mark to know that your hoist is safe to use in environments with combustible gases, vapours and dusts.

### Conforms to ATEX Standards

The RCB hand chain hoist conforms to the European ATEX directive 94/9/EC for certified use in potentially explosive atmospheres. ATEX is a multi-level technical standard mandatory in the European Economic Area (EEA) for using equipment in dust-laden or explosive environments.

### Spark-Resistant Hand & Load Chain

The same premium chain as on any Kito hoist but with added protection from accidental sparks. The RCB comes standard with our stainless steel hand chain and nickel-plated load chain.

### Spark-Resistant Copper Plated Bottom Hook

From top to bottom, the RCB protects you with added safety features like the standard copper-plated bottom hook designed to resist sparks at the point of contact.

### Maximum equipment temperature 135 °C

Potentially explosive atmospheres often relate to high temperatures. The RCB is proven to take the heat and safely operate at temperatures as high as 135°C.

### Optional Spark-Resistant Trolley Wheels

The RCB can be optionally paired with a plain or geared trolley that is also equipped with spark-resistant features. Solid bronze trolley wheels are available on models 2t and lower; and bronze-plated trolley wheels are available on the 3t model.



# RCB SERIES

## CAPACITY

- ½ to 3 metric tonnes

## STANDARDS

- ASME B30.16 Safety Standard
- ASME HST-2 Performance Standard
- Conforms to ATEX directive 94/9/EC
- Specification: EX II 2G c IIB T4 and EX II 2D c T135
- At rated capacity, load-bearing parts are only stressed to 25% of their limit

## STANDARD OPTIONS

- Custom lift lengths to suit your requirements
- Plain or Geared trolley mount for improved load control

## SPARK-RESISTANT OPTIONS

- Nickel-plated load chain and stainless steel hand chain
- Copper-plated load hook
- Solid bronze trolley wheels on models 2t and lower
- Bronze plated trolley wheels on 3t model

•

## BODY

- Durable over-sized body with all-steel construction
- Rugged gear case and hand wheel cover
- Compact design for low headroom and lightweight portability

## HAND CHAIN

- Stainless steel hand chain

## LOAD CHAIN

- Grade 100 nickel-plated
- High-impact steel chain guide
- Standard Lift: 8 feet

## HOOKS

- Copper plated bottom hook
- Self-closing top and bottom hooks with heavy-duty hook latch

## OPERATION

- Hand chain operated
- Reduced operator fatigue through efficient drive train

## GEARS

- Double reduction gearing requiring very low effort to operate
- Induction heat-treated and case-hardened
- Enclosed to protect from dust and water

## BEARINGS

- Maintenance-free sealed bearings increase reliability and reduce required pull force to lift loads

## BRAKE

- Double pawl springs for extremely reliable operation and instant brake activation
- Enclosed to protect from dust, rain and dirt

## OPERATING CONDITIONS

- Recommended for -40° C to +60° C

# RCB ATEX HAND CHAIN HOIST PLAIN TROLLEY MOUNT

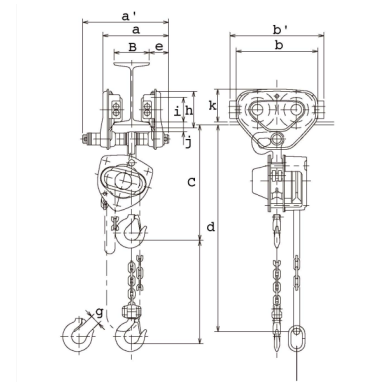

## DIMENSIONS

Capacity (tonne)	Model	C	a	a'	b	b'	d	e	f	g	h	i	j	k
½	RCBSP005	305	215	249	236	272	2500	56	2200	29	106	71	28	95
1	RCBSP010	365	218	300	280	316	2500	69	2200	34	127	85	34	112
2	RCBSP020	535	280	320	324	374	3100	79	2700	42.5	148	100	36	134
3	RCBSP030	660	273	297	400	450	3600	53	3200	46.5	169	118	47	144

## SPECIFICATIONS

Capacity (tonne)	Model	Standard Lift (ft)	Chain Pulled to Lift Load One Meter (m)	Load Chain Falls	Load Chain Code	Hand Chain Falls	Hand Pull to Lift Full Load (kg)	Load to Engage High Speed (tonne)	Flange Width (in)	Headroom (in)	Ship Weight (lbs)	Weight Per 5 ft of Lift (lbs)
½	RCBSP005	10	43	1	KCF063-NP	2	29	-----	2.25-5"	12	42	6
1	RCBSP010	10	57	1	KCF071-NP	2	35	-----	3.25-6"	14	62	7
2	RCBSP020	10	114	2	KCF071-NP	2	36	-----	3.25-6"	21	99	11
3	RCBSP030	10	198	2	KCB3090-NP	2	34	-----	4-7"	24	194	15

# RCB ATEX HAND CHAIN HOIST GEARED TROLLEY MOUNT

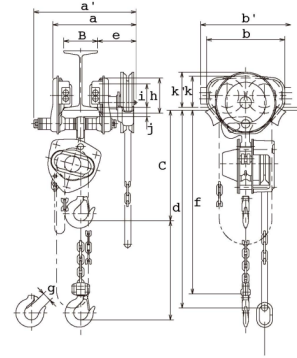

## DIMENSIONS

Capacity (tonne)	Model	C	a	a'	b	b'	d	e	f	g	h	i	j	k	k'
½	RCBSG005	305	275	309	236	272	2500	116	2200	29	106	71	28	95	106
1	RCBSG010	365	349	385	280	316	2500	154	2200	34	127	85	34	112	109
2	RCBSG020	535	359	398	324	374	3100	157	2700	42.5	148	100	36	134	114
3	RCBSG030	660	377	401	400	450	3600	156	3200	46.5	169	118	47	144	131

## SPECIFICATIONS

Capacity (tonne)	Model	Standard Lift (ft)	Chain Pulled to Lift Load One Meter (m)	Load Chain Falls	Load Chain Code	Hand Chain Falls	Hand Pull to Lift Full Load (kg)	Load to Engage High Speed (tonne)	Flange Width (in)	Headroom (in)	Ship Weight (lbs)	Weight Per 5 ft of Lift (lbs)
½	RCBSG005	10	43	1	KCF063-NP	2	29	-----	2.25-5"	12	54	6
1	RCBSG010	10	57	1	KCF071-NP	2	35	-----	3.25-6"	14	72	7
2	RCBSG020	10	114	2	KCF071-NP	2	36	-----	3.25-6"	21	108	11
3	RCBSG030	10	198	2	KCB3090-NP	2	34	-----	4-7"	24	205	15